

## Local extraction devices

### Extraction arm

#### Intended use

- For the extraction of a specific area
- For fixing to service wings, service spines or the wall

#### Design

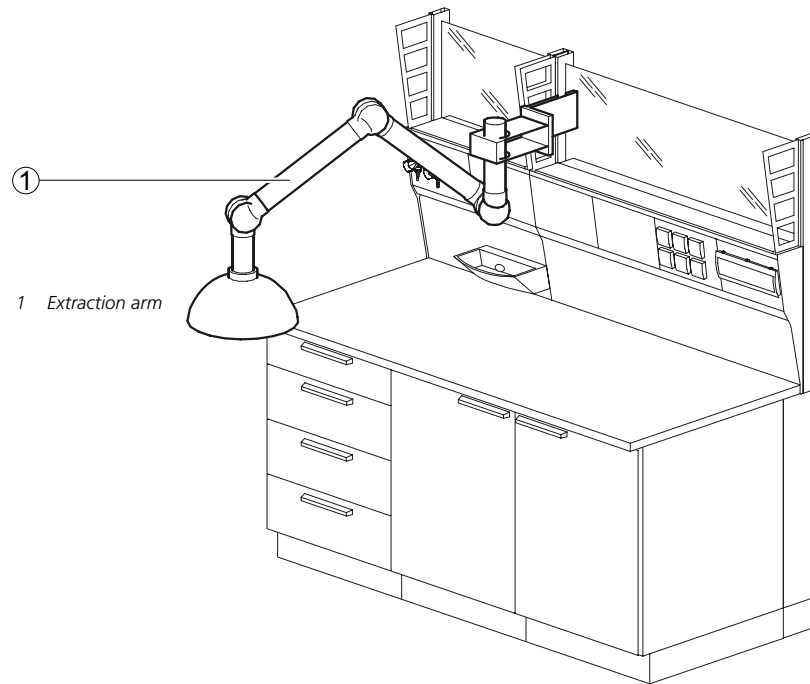

#### Technical data

Dimension	50	75
Pipe system Ø [mm] <sup>1)</sup>	50	75
Coupling hood Ø [mm]	350	
Extraction maximum [mm]	50	75

<sup>1)</sup> Pipe system Ø 50 mm only for fastening to the service wing

Ventilation technology	50	75
Minimum air exchange rate [m³/h]	50	100
Admission pressure [Pa]	150	
Admission pressure [Pa] with Waldner airflow damper	200	

Material	
Pipe	Anodised aluminium
Hinged bracket	Polypropylene
Coupling hood	Polycarbonate
Suction tip	Anodised aluminium